

065-79LXEDMG Small Form-factor Pluggable (SFP) Gigabit Interface Module



The Signamax 065-79LXEDMG is a Small Form-factor Pluggable (SFP) singlemode fiber module that supports Gigabit Ethernet over singlemode fiber cable at distances up to 40 kilometers. It adheres to the IEEE 802.3z standard for Gigabit Ethernet over singlemode fiber at 1310 nm, and is a cost-effective method of providing changeable Gigabit Ethernet singlemode interfaces to switches and media converters equipped with a standard SFP slot. This model supports a temperature range of 0° C to 70° C for normal applications.

Applications

- Router / Server interface
- Distributed multi-processing
- Hardened Switch to switch interface
- High speed I/O for file server

Key Features

- Compliant with SFP MultiSource Agreement. Compliant with IEEE802.3Z
- SCA-2 Host connector
- Duplex LC connector
- 1310 nm DFB Laser
- 3.3V power supply
- Hot-Pluggable capability
- Extended EMI & ESD protection
- Class 1 laser product complies with EN 60825-1

Ordering Information

Part Number	Description
065-79LXEDMG	1000BaseLX SFP Module – SM/LC, 40 km

Summary Specification

PART NUMBER	Model / Spectrum	Light Source	Link Power Budget	Typical Max. Distance**	Supply Voltage	Operating Temp.
065-79LXEDMG	LX 1310 nm	DFB Laser	22 dBm	40 km	3.3V	0 ~ 70 °C

** Maximum distances attainable on singlemode fiber circuits are dependent upon a circuit's conditions; i.e., the number of splices and patch panels and the number of bends in the circuit path. For comparison with competing products, please use the Link Power Budget for meaningful comparisons.

SPECIFICATIONS

DETAILED SPECIFICATIONS

• **APPLICABLE STANDARDS**

IEEE 802.3z (1000BaseLX Gigabit Ethernet)

• **ABSOLUTE MAXIMUM RATINGS**

Storage Temperature: TS -40 -- 85 °C

Supply Voltage: V_{CC} -0.5 -- 6.0 V

Input Voltage: V_{IN} -0.5 -- V_{CC} V

Operating Humidity: 0-85 %

• **RECOMMENDED OPERATING CONDITIONS**

PARAMETER	SYMBOL	MIN	MAX	UNITS	NOTE
Ambient Operating Temperature	T _{AMB}	0	70	°C	
Supply Voltage	V _{CC}	3.1	3.5	V	
Supply Current (3.3V)	I _{TX} + I _{RX}	200	300	mA	

• **TRANSMITTER ELECTRO-OPTICAL CHARACTERISTICS**

V_{CC} = 3.1 V to 3.5V, T_A = 0 °C to 70 °C

PARAMETER	SYMBOL	MIN	TYP.	MAX	UNITS	NOTE
Transmitter Differential Input Voltage	TD +/-	400		2000	mVp-p	A
Optical Output Power	PO	-2		+3	dBm	A
Optical Extinction Ratio	ER	9			dB	A
Center Wavelength	λ _C	1280	1310	1355	nm	A
Spectral Width	Δλ			<1	nm	A
Side Mode Suppression Ratio	SMSR			30	dB	A
Optical Rise / Fall Time	tr / tf			0.25	nsec	A,B
Tx_Fault - High	VFault_H	2		V _{CC}	V	A
Tx_Fault - Low	VFault_L	V _{EE}		V _{EE} +0.5	V	A
Tx_Disable - High	VDisable_H	2		V _{CC}	V	A
Tx_Disable - Low	VDisable_L	V _{EE}		V _{EE} +0.8	V	A

Notes:

A. All data is measured at 1250 Mbps, PRBS 2⁷-1, NRZ.

B. 20%~80%

• **RECEIVER ELECTRO-OPTICAL CHARACTERISTICS**

V_{CC} = 3.1 V to 3.5 V, T_A = 0 °C to 70 °C

PARAMETER	SYMBOL	MIN	TYP.	MAX	UNITS	NOTE
Receiver Differential Output Voltage	RD +/-	600	800		mVP-P	
Receiver Overload	PINMAX	-3			dBm	A,B
Receiver Sensitivity	PINMIN			-24	dBm	A,B
Operating Center Wavelength	λ _C	1270		1620	nm	
Receiver LOS Assert Level	PRX_LOS A	-35			dBm	B
Receiver LOS Deassert Level	PRX_LOS D			-24.5	dBm	B
Receiver Loss of Signal Hysteresis		0.5	2		dB	B

Notes:

A. With BER better than or equal to 1×10⁻¹²

B. measured in the center of the eye opening with 2⁷-1 PRBS, NRZ

DETAILED SPECIFICATIONS (continued)

• **DIMENSIONS (mm)**

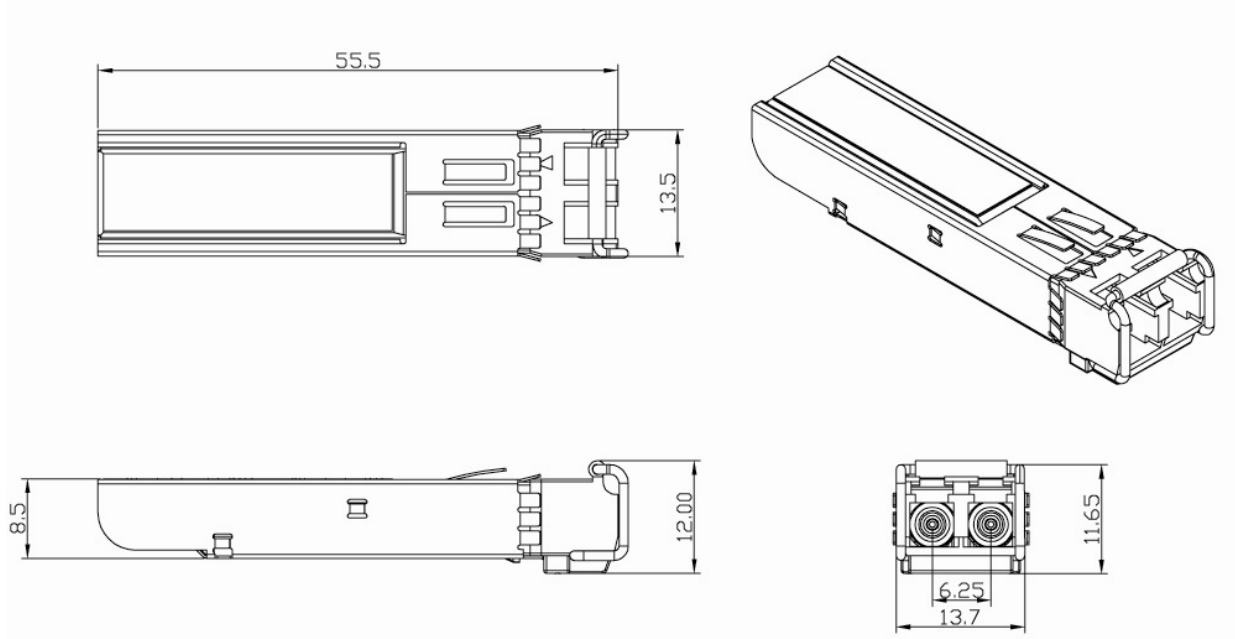

• **REGULATORY COMPLIANCE**

Feature	Test Method	Performance
Electrostatic Discharge (ESD) to optical connector	Variation of IEC 61000-4-2	Typically withstand at least 15kV without damage when port is contacted by Human Body Model probe.
Immunity	Variation of IEC 61000-4-3	Typically show no measurable effect from a 10 V/m field swept from 27 MHz to 1 GHz applied to the transceiver without a chassis enclosure.
Electromagnetic Interference (EMI)	FCC Class B CENELEC EN55022 Class B (CISPR 22A)	Margins are dependent on customer board and chassis design.
Laser Eye Safety	FDA21 CFR 1040.10 and 1040.11	Class 1 Laser Safety product.

• **WARRANTY**
 Lifetime